

NEW BUILDING FOUR FOR:
SOUTH PARK AT 54
5011 SOUTHPARK DRIVE
DURHAM, NORTH CAROLINA

MAURER ARCHITECTURE
226 EAST MARTIN STREET, RALEIGH, NC 27601
TEL. 919-829-4969 FAX 919-829-0860

| | |
|-----------|---------|
| DATE | 6.27.04 |
| DR. | AJO |
| CH. | DSM |
| PROJ. # | 0419 |
| REVISIONS | DATE |
| | |
| | |
| | |

SECOND FLOOR
PLAN & DETAILS

A1.2

DRAFTSTOPPING NOTES:

- INSTALL 1/2" GNB DRAFTSTOPPING IN FLOOR/CEILING ASSEMBLY SO THAT HORIZONTAL AREAS DO NOT EXCEED 9000 SF.
- ALL DRAFT STOPS SHALL BE CONSTRUCTED IN THE ATTIC SPACE BY ATTACHING 1/2" GNB TO ONE SIDE OF ROOF TRUSSES AT LOCATIONS SHOWN ON ROOF PLAN. (ATTIC AREAS SHALL BE SEPARATED INTO 3000 SF. OR LESS SPACES PER 16.4.3 OF 2000 IBC/C 2002.)

MALL LEGEND-2ND FLOOR

NEW 1-HR MALL - 2x4 WOOD STUDS WITH 1 LAYER OF 5/8" TYPE 'X' GNB EACH SIDE TIGHT TO TRUSSES WITH BATT INSULATION. 1/2" GNB FACING INT. SHALL BE INSTALLED BY TENANT.

NEW SHEAR MALL & FIRE BARRIER - (2) LAYERS OF 5/8" GNB EACH SIDE OF 2x4 WOOD STUD WALL FROM FIRST FLOOR SLAB TO UNDERSIDE OF ROOF TRUSSES PER U.L. 1801.

ALL BY TENANT.

| DOOR SCHEDULE | MATERIAL | FRAME | RATIOS | HARDWARE | NOTES |
|---------------|----------|--------------------------------|--------|--------------|---|
| 201 | 60"x80" | HC STEEL, PTD | 1/2" | PTD RH1 HOUR | LEVER LOCKSET W/ DEADBOLT PROVIDE WOOD CASING OVER H.K. FRAME |
| 202 | 30"x48" | PRE-FAB & PANEL, HC STEEL, PTD | 1/2" | PTD RH1 HOUR | LEVER LOCKSET W/ DEADBOLT PROVIDE WOOD CASING OVER H.K. FRAME |
| 203 | 30"x48" | PRE-FAB & PANEL, HC STEEL, PTD | 1/2" | PTD RH1 HOUR | LEVER LOCKSET W/ DEADBOLT PROVIDE WOOD CASING OVER H.K. FRAME |
| 204 | 30"x48" | PRE-FAB & PANEL, HC STEEL, PTD | 1/2" | PTD RH1 HOUR | LEVER LOCKSET W/ DEADBOLT PROVIDE WOOD CASING OVER H.K. FRAME |
| 205 | 30"x48" | PRE-FAB & PANEL, HC STEEL, PTD | 1/2" | PTD RH1 HOUR | LEVER LOCKSET W/ DEADBOLT PROVIDE WOOD CASING OVER H.K. FRAME |
| 206 | 30"x48" | PRE-FAB & PANEL, HC STEEL, PTD | 1/2" | PTD RH1 HOUR | LEVER LOCKSET W/ DEADBOLT PROVIDE WOOD CASING OVER H.K. FRAME |
| 207 | 30"x48" | PRE-FAB & PANEL, HC STEEL, PTD | 1/2" | PTD RH1 HOUR | LEVER LOCKSET W/ DEADBOLT PROVIDE WOOD CASING OVER H.K. FRAME |

NOTES:

- ALL DOOR HARDWARE TO BE KINNESEY LEVER W/ BATTEN FINISH.
- ALL DOOR HARDWARE TO BE KINNESEY LEVER W/ BATTEN FINISH.
- ALL DOOR HARDWARE TO BE KINNESEY LEVER W/ BATTEN FINISH.
- ALL DOOR HARDWARE TO BE KINNESEY LEVER W/ BATTEN FINISH.

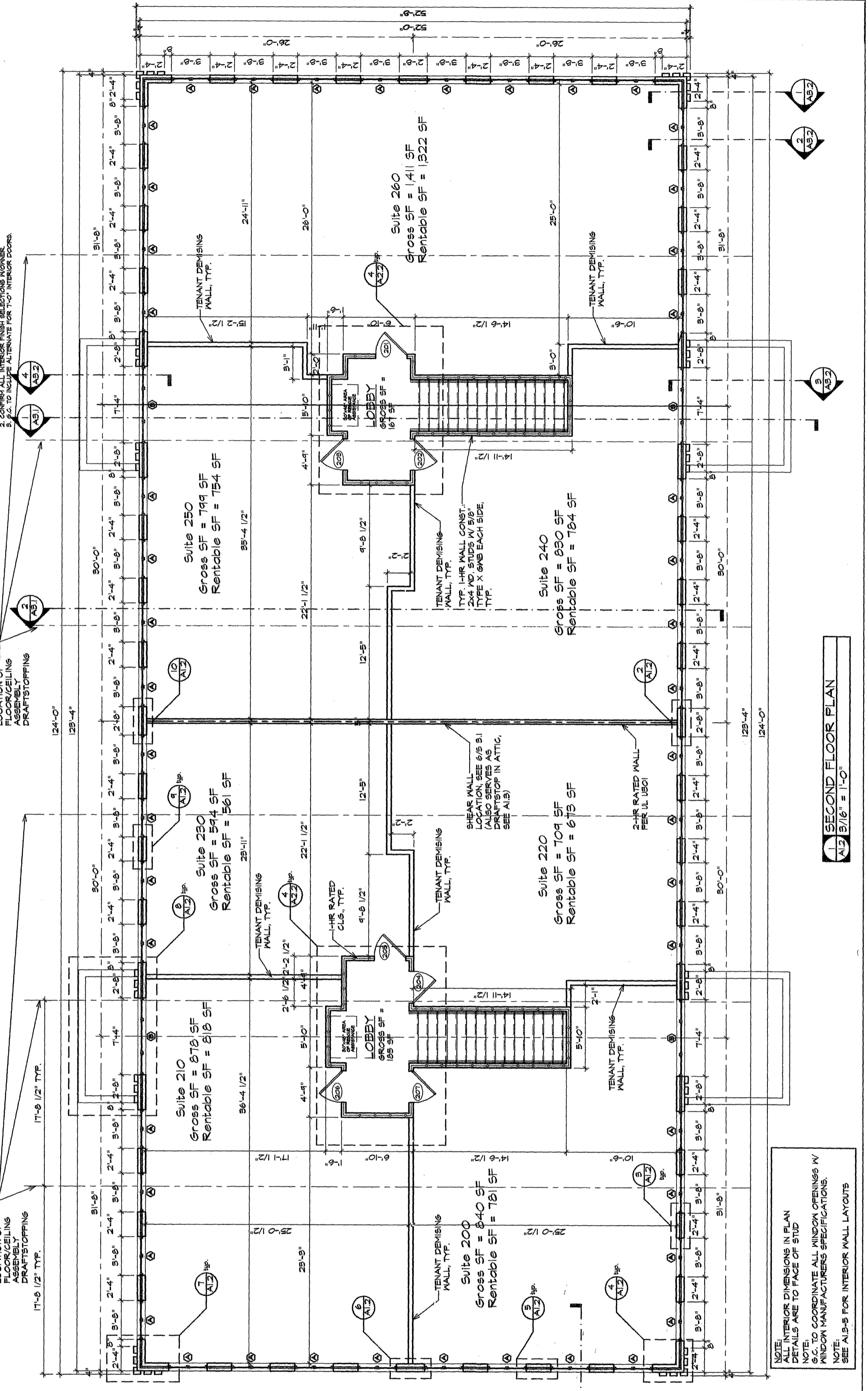
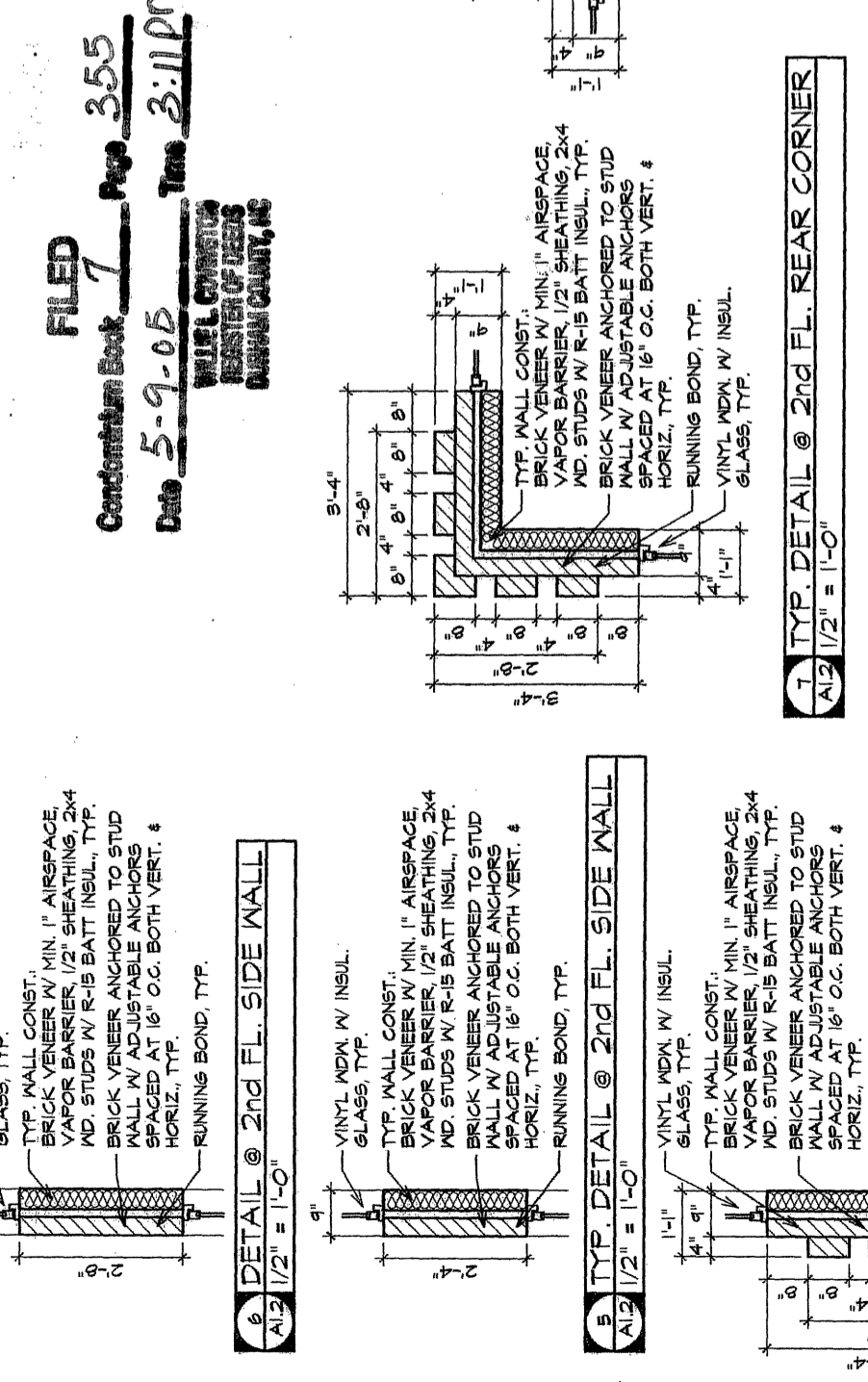
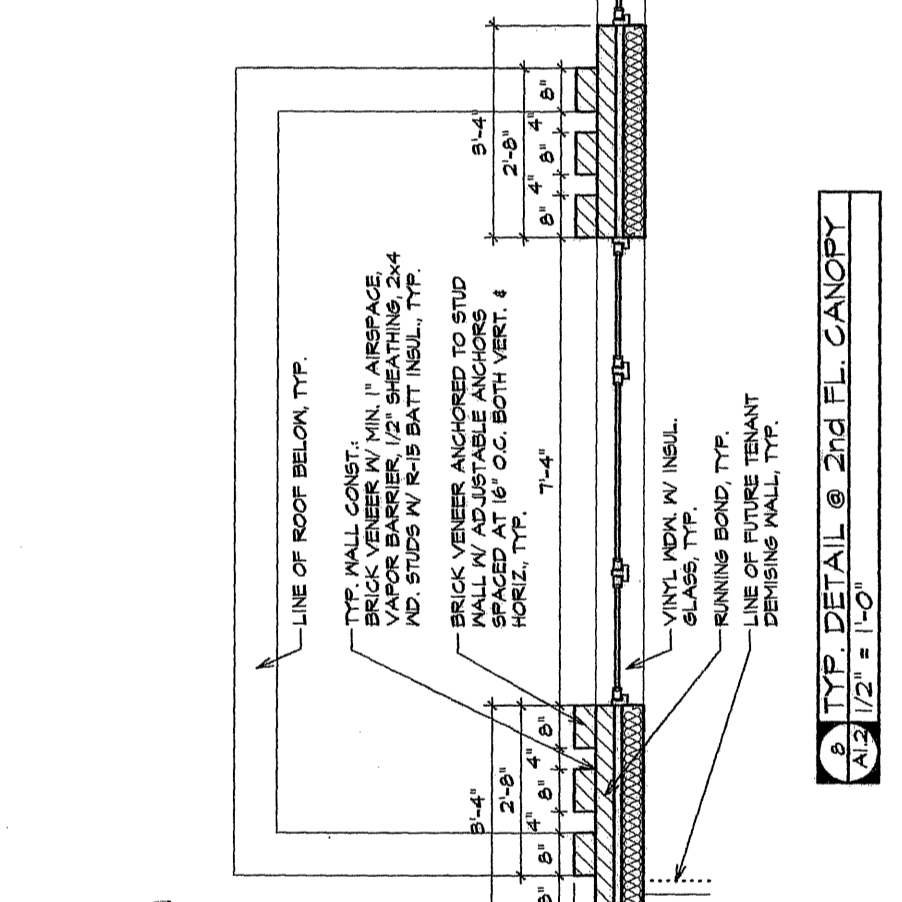
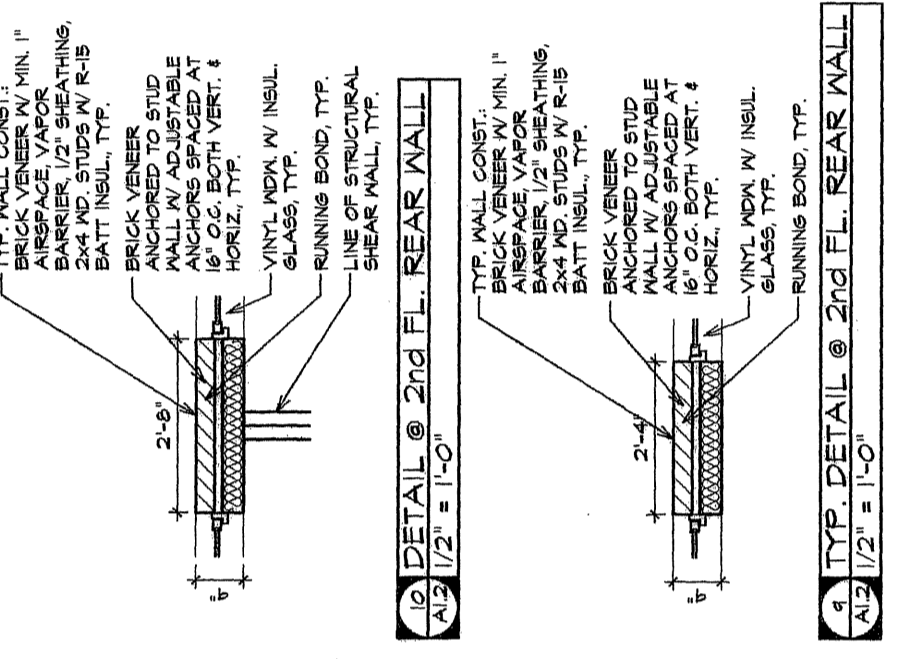

FILED
Condominium Book 7 Page 355
Date 5-9-05 Time 3:11 PM
REGISTERED RECORDS
NORTH CAROLINA
COUNTY, NC

NOTE: INTERIOR DIMENSIONS IN PLAN DETAILS ARE TO FACE OF STUD.
NOTE: G.C. TO COORDINATE ALL WINDOW OPENINGS W/ WINDOW MANUFACTURERS SPECIFICATIONS.
NOTE: SEE A1.5-B FOR INTERIOR WALL LAYOUTS

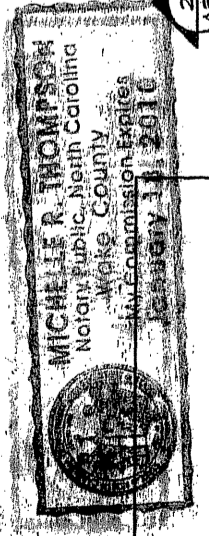

North Carolina
Michelle R. Thompson
Notary Public
These drawings depict the original design documents that were submitted for building permit. Any modifications made during construction. Callings are not constructed and shall be part of future interior upfits. (Amicapped to be as 11-07)

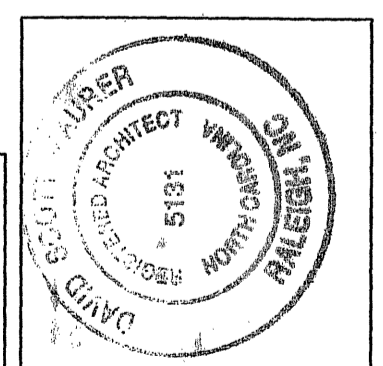

My commission expires January 18, 2010
I, David Maurer, certify that these plans or plans fully and accurately depict the layout, location, ceiling and floor elevations, unit numbers and dimensions of the units as built.
Date: 7/31/05
These drawings depict the original design documents that were submitted for building permit. Any modifications made during construction. Callings are not constructed and shall be part of future interior upfits. (Amicapped to be as 11-07)



Willie L. Covington
Register of Deeds
Durham County, North Carolina

CONDO



FOR REGISTRATION REGISTER OF DEEDS
Willie L. Covington
DURHAM COUNTY, NC
2005 MAY 09 03:11:46 PM
BK:7 PG:355-357 FEE:\$21.00

INSTRUMENT # 2005019853

GRANTOR(S) SOUTH PARK OFFICE PARTNERS LLC
OWNER(S): _____

3 of 4



WILLIE L. COVINGTON
REGISTER OF DEEDS, DURHAM COUNTY
DURHAM COUNTY COURTHOUSE
200 E. MAIN STREET
DURHAM, NC 27701

PLEASE RETAIN YELLOW TRAILER PAGE

It is part of recorded document, and must be submitted with original for re-recording
and/or cancellation.

Filed For Registration: 05/09/2005 03:11:46 PM
Book: CONDO 7 Page: 355-357
Document No.: 2005019853
CONDO 3 PGS \$21.00
Recorder: APRIL J WILLIAMS

State of North Carolina, County of Durham

WILLIE L. COVINGTON, REGISTER OF DEEDS

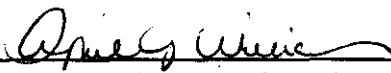
By: 
Deputy/Assistant Register of Deeds



2005019853