

**Orange County North Carolina**

278663  
112 NC 54

**MAILING ADDRESS**  
CARRBORO BERKSHIRE WEST LLC  
5605 GLENDRIGE DR STE 1010  
ATLANTA GA 30342

Total Assessed Value  
**\$15,431,300**

**KEY INFORMATION**

Tax Year	<b>2021</b>		
Parcel ID	<b>9778178992</b>	Township	<b>7 - CHAPEL HILL</b>
Land Size	<b>14.38</b>	Land Units	<b>AC</b>
Rate Code	<b>21</b>		
District Codes	<b>CH CHSchoolDst., G0 County, G1 Carrboro</b>		
Property LUC	<b>Multifamily-Improved</b>		
Neighborhood	<b>L001 - CHCOMMERCIA</b>		
Legal Description	<b>W/S 54 BY-PASS</b>		
Exempt Type	<b>-</b>		

**APPRAISAL DETAILS**

Total Land	<b>\$10,209,800</b>
Ag Credit	<b>-</b>
Land	<b>\$10,209,800</b>
Building	<b>\$5,170,000</b>
Yard Items	<b>\$51,500</b>
Market Total	<b>\$15,431,300</b>
Total Assessed	<b>\$15,431,300</b>

**RESIDENTIAL**

Orange County North Carolina

266139

**MAILING ADDRESS**  
CARRBORO BERKSHIRE EAST LLC  
5605N GLENRIDGE DR STE 1010  
ATLANTA GA 30342

Total Assessed Value  
**\$9,985,400**

KEY INFORMATION

Tax Year	<b>2021</b>		
Parcel ID	<b>9778286372</b>	Township	<b>7 - CHAPEL HILL</b>
Land Size	<b>7.75</b>	Land Units	<b>AC</b>
Rate Code	<b>21</b>		
District Codes	<b>G0 County, G1 Carrboro, CH CHSchoolDst.</b>		
Property LUC	<b>Multifamily-Improved</b>		
Neighborhood	<b>L001 - CHCOMMERCIA</b>		
Legal Description	<b>S/O HWY 54</b>		
Exempt Type	<b>-</b>		

APPRAISAL DETAILS

Total Land	<b>\$6,820,000</b>
Ag Credit	<b>-</b>
Land	<b>\$6,820,000</b>
Building	<b>\$3,117,700</b>
Yard Items	<b>\$47,700</b>
Market Total	<b>\$9,985,400</b>
Total Assessed	<b>\$9,985,400</b>

RESIDENTIAL

BUILDING (1)					
Type	<b>Apt-Multi</b>	Total Value	<b>\$416,100</b>	Finished Sq Ft	<b>11,200 sf</b>
Style	<b>-</b>	Quality	<b>Grade C</b>	Condition	<b>Average</b>
Year Built	<b>1972</b>	Exterior Walls		Full Bath	<b>0</b>
Roof Cover		Half Bath	<b>0</b>	HVAC	
Bedrooms	<b>-</b>	Garage Type	<b>-</b>		
BUILDING (2)					
BUILDING (3)					
BUILDING (4)					
BUILDING (5)					
BUILDING (6)					
BUILDING (7)					
BUILDING (8)					
BUILDING (9)					

MISC IMPROVEMENTS

IMPROVEMENT TYPE	UNITS/SQ FT	EST YEAR BUILT	APPRAISED VALUE
POOL C (IRRE	1	-	\$26,400
BATH HSE A4	448	-	\$21,300

### SALES

SALE DATE	SALE PRICE	DEED BOOK	DEED PAGE	INSTRUMENT TYPE	GRANTOR
12/14/2017	\$9,531,000	6402	84		NORTH CAROLINA CARRBORO LIMITED
06/20/2003	\$3,250,000	3066	588		BERKSHIRE MANOR
06/20/2003	\$3,250,000	3066	588		BERKSHIRE MANOR LLC
06/09/1998	\$0	1744	110		FAIRFAX VILLAGE INC
06/09/1998	\$0	1744	110		FAIRFAX VILLAGE

### YARD ITEMS

DESCRIPTION	TOTAL UNITS	YEAR BUILT	LENGTH	WIDTH	HEIGHT
No items to display					

### LAND

UNIT / SOIL TYPE	DESCRIPTION	USE CODE	ACRES / LOTS	VALUE
C_AC	Com Acres	SITE	7.75	\$6,820,000

### VALUE HISTORY

YEAR	TOTAL MARKET VALUE
2020	\$4,477,000
2019	\$4,477,000
2018	\$4,477,000
2017	\$4,477,000
2016	\$3,871,202
2015	\$3,871,202
2014	\$3,871,202
2013	\$3,871,202
2012	\$3,871,202
2011	\$3,871,202

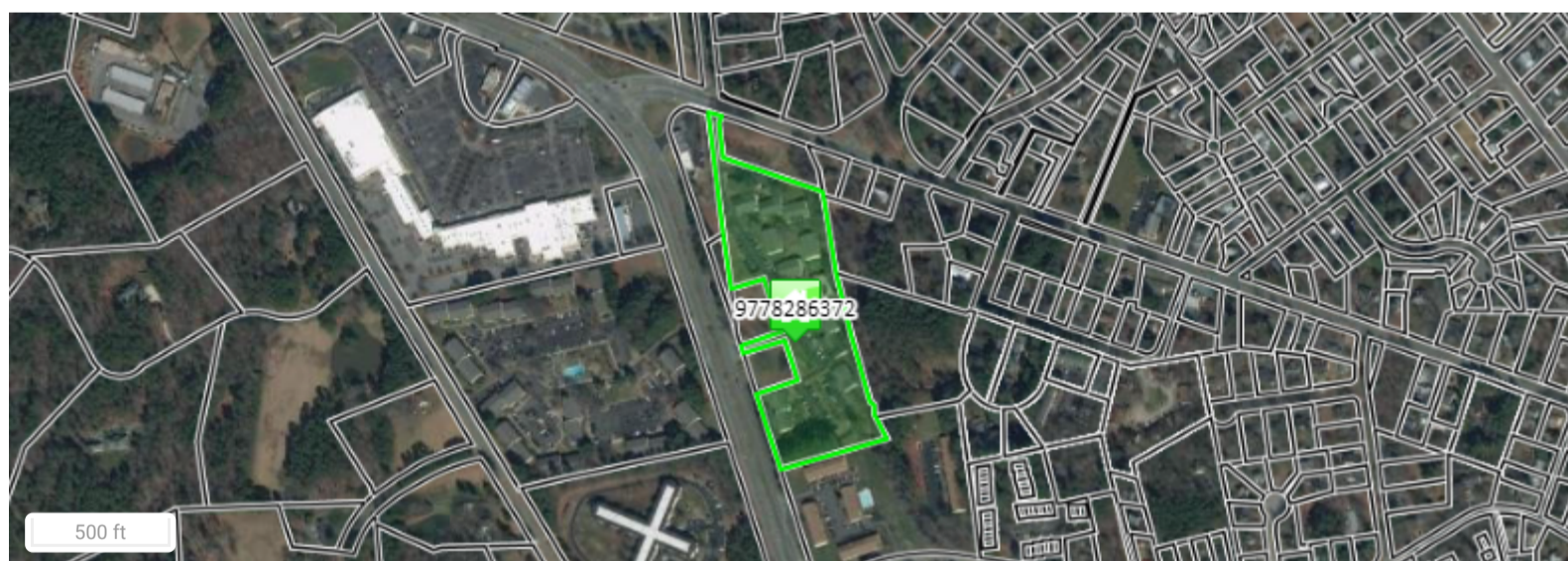

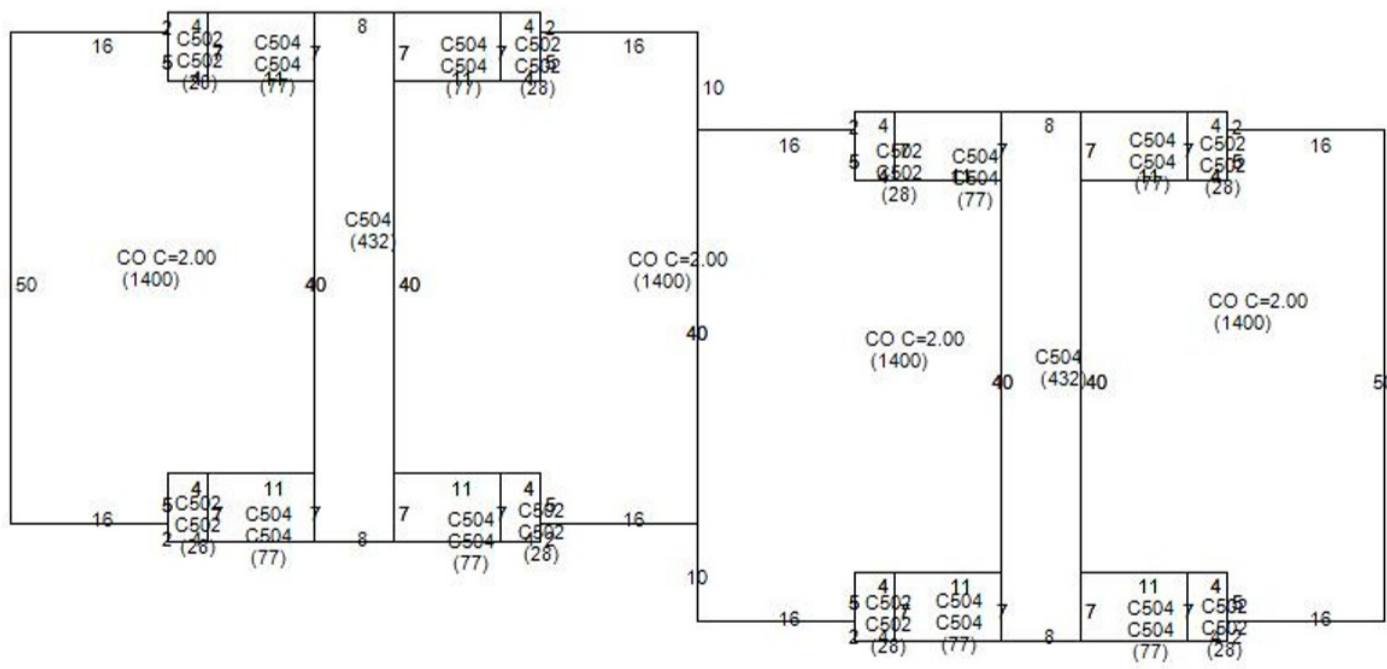
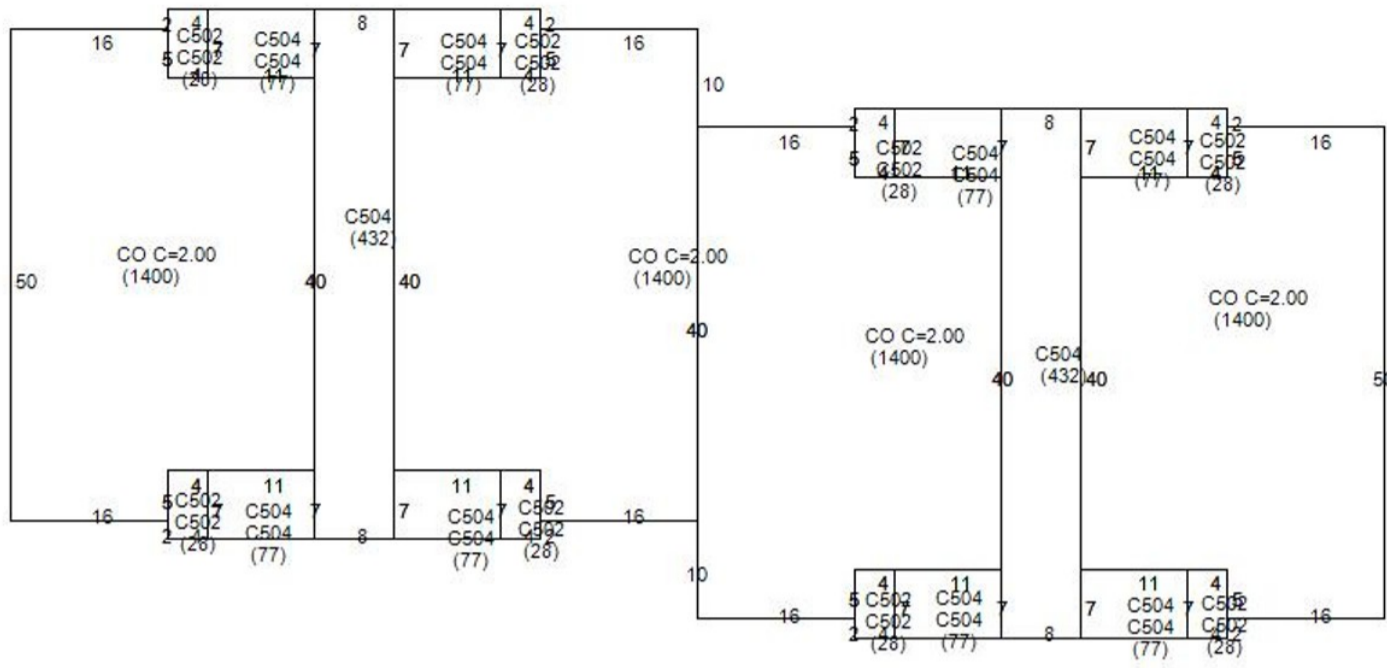

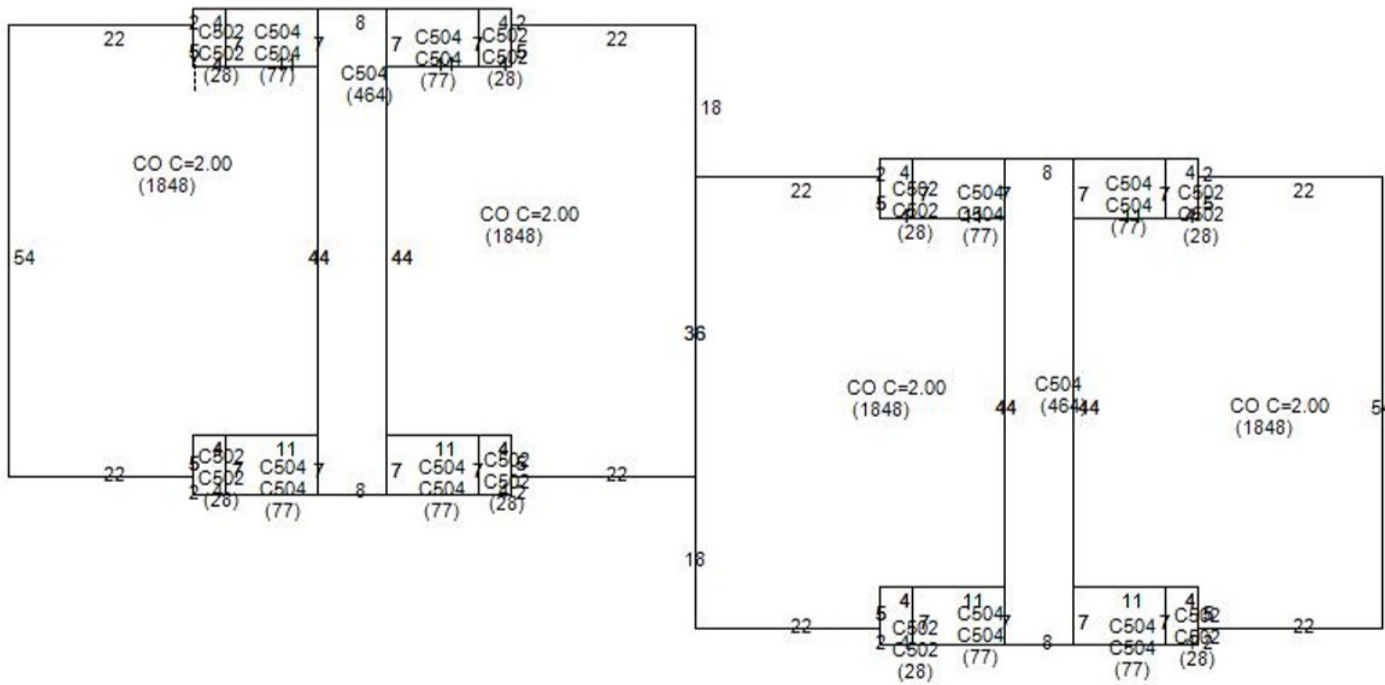
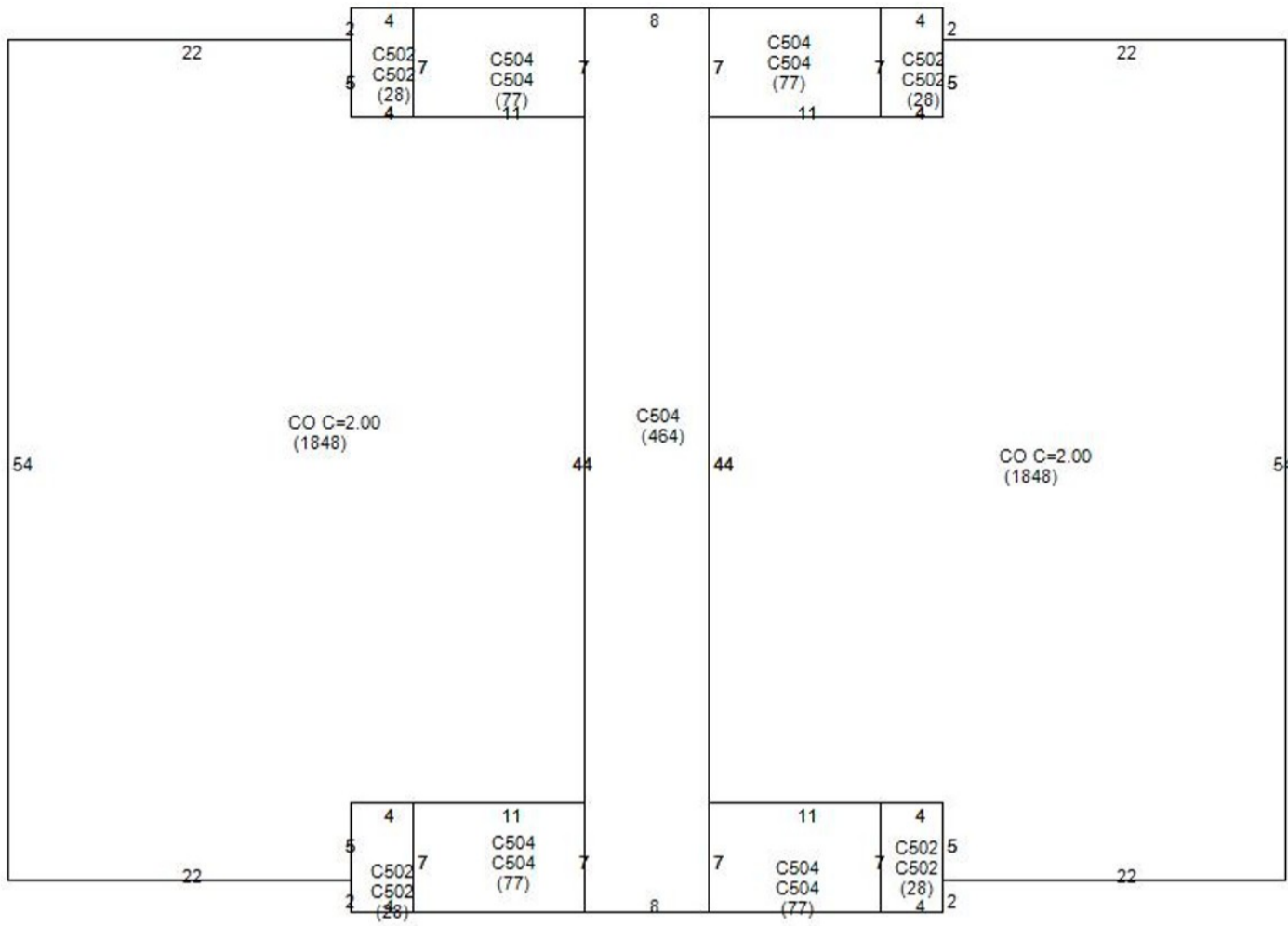

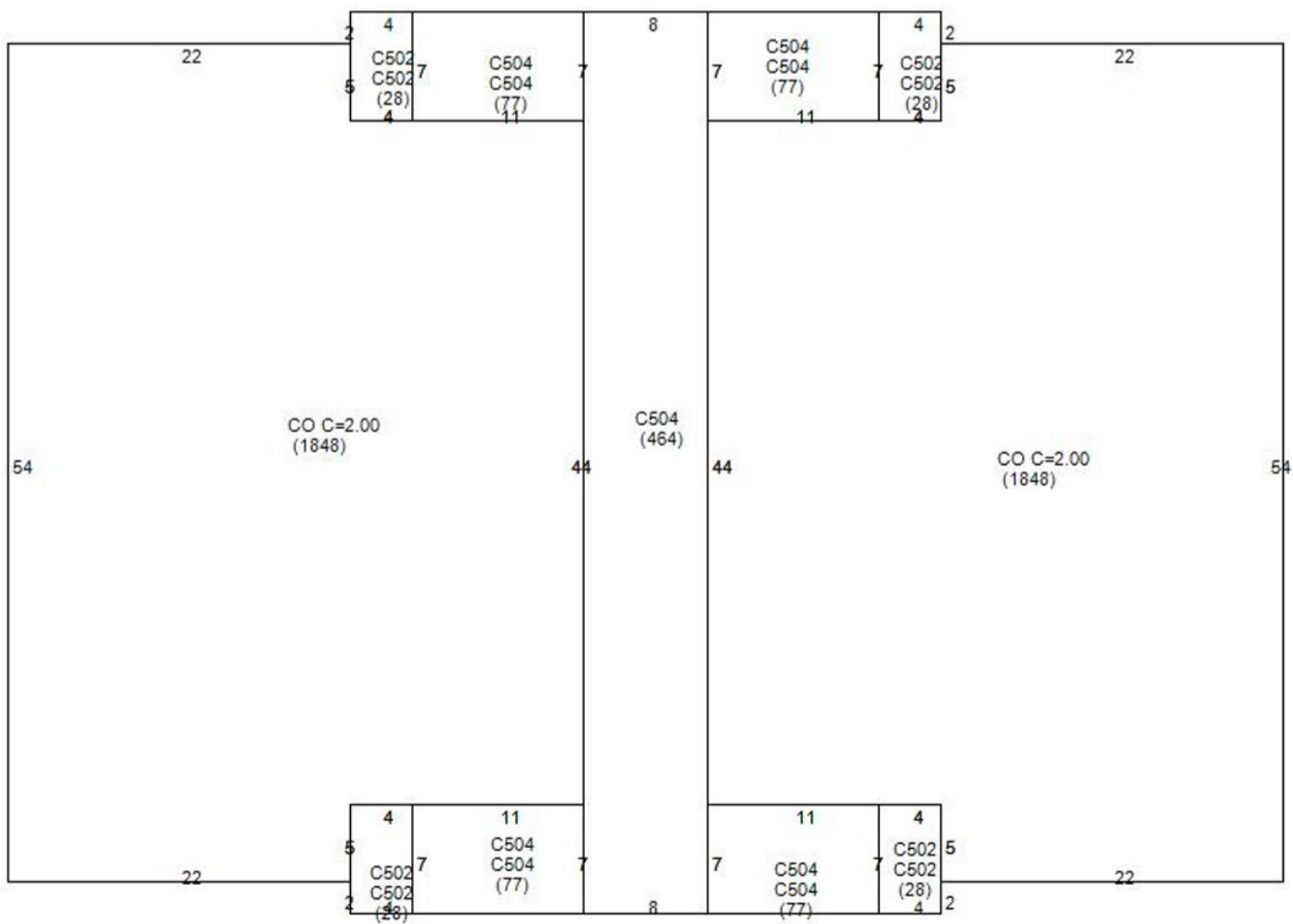
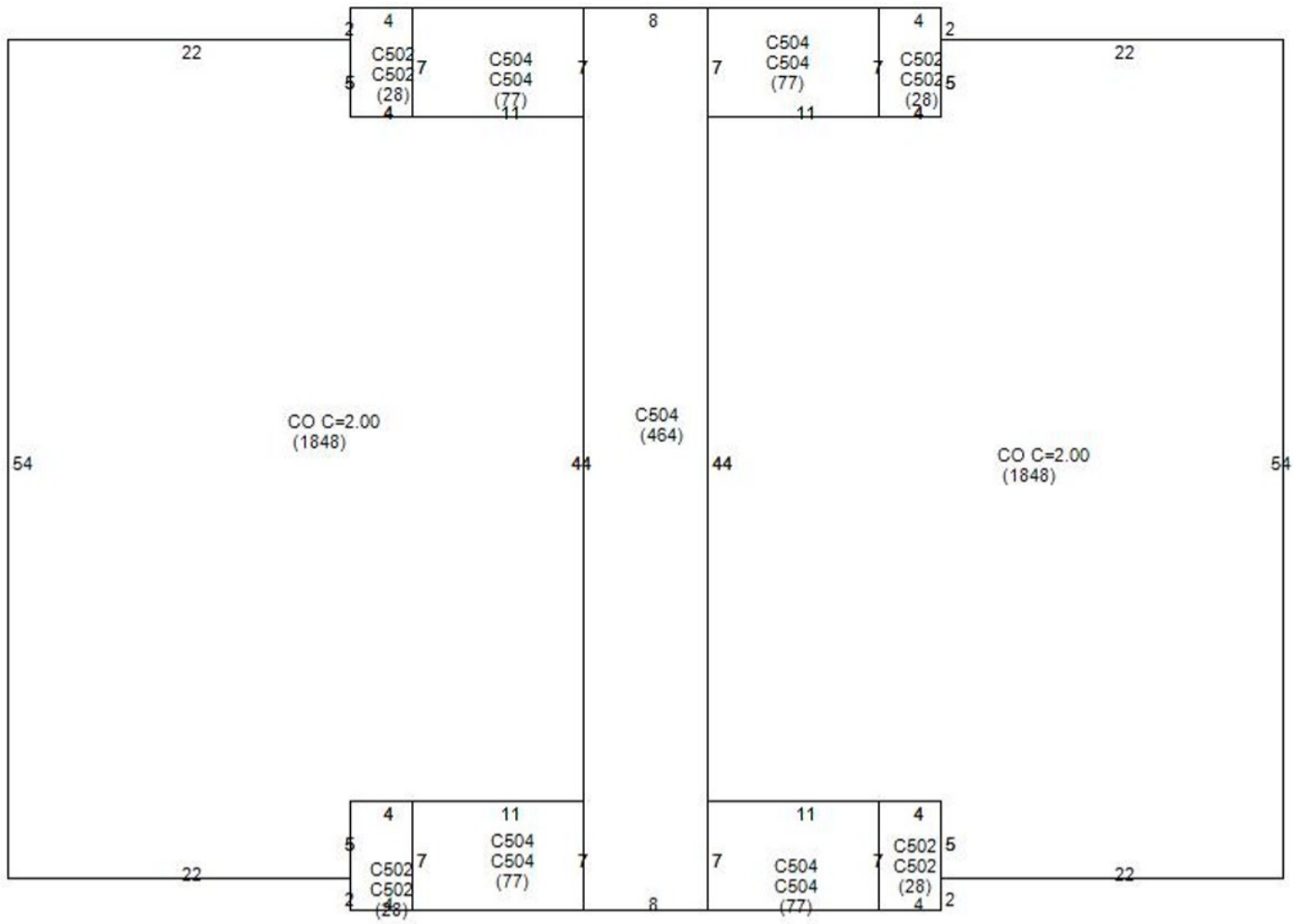

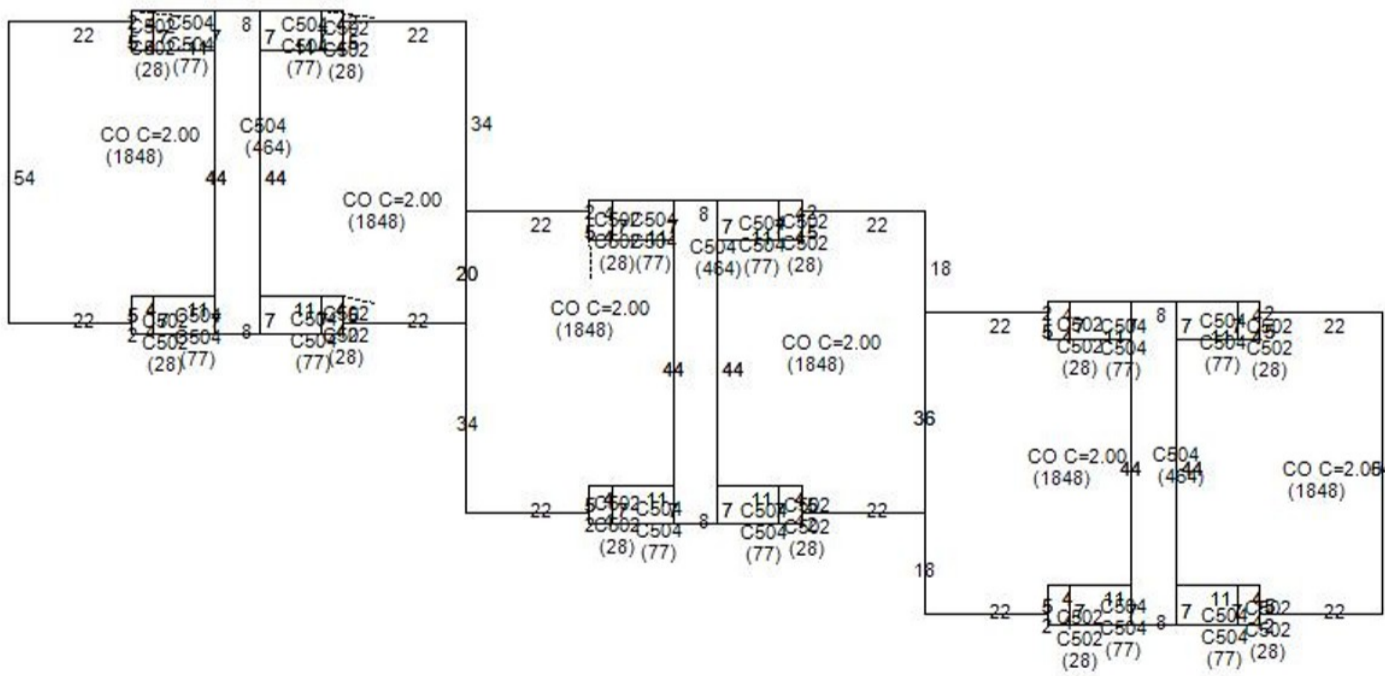
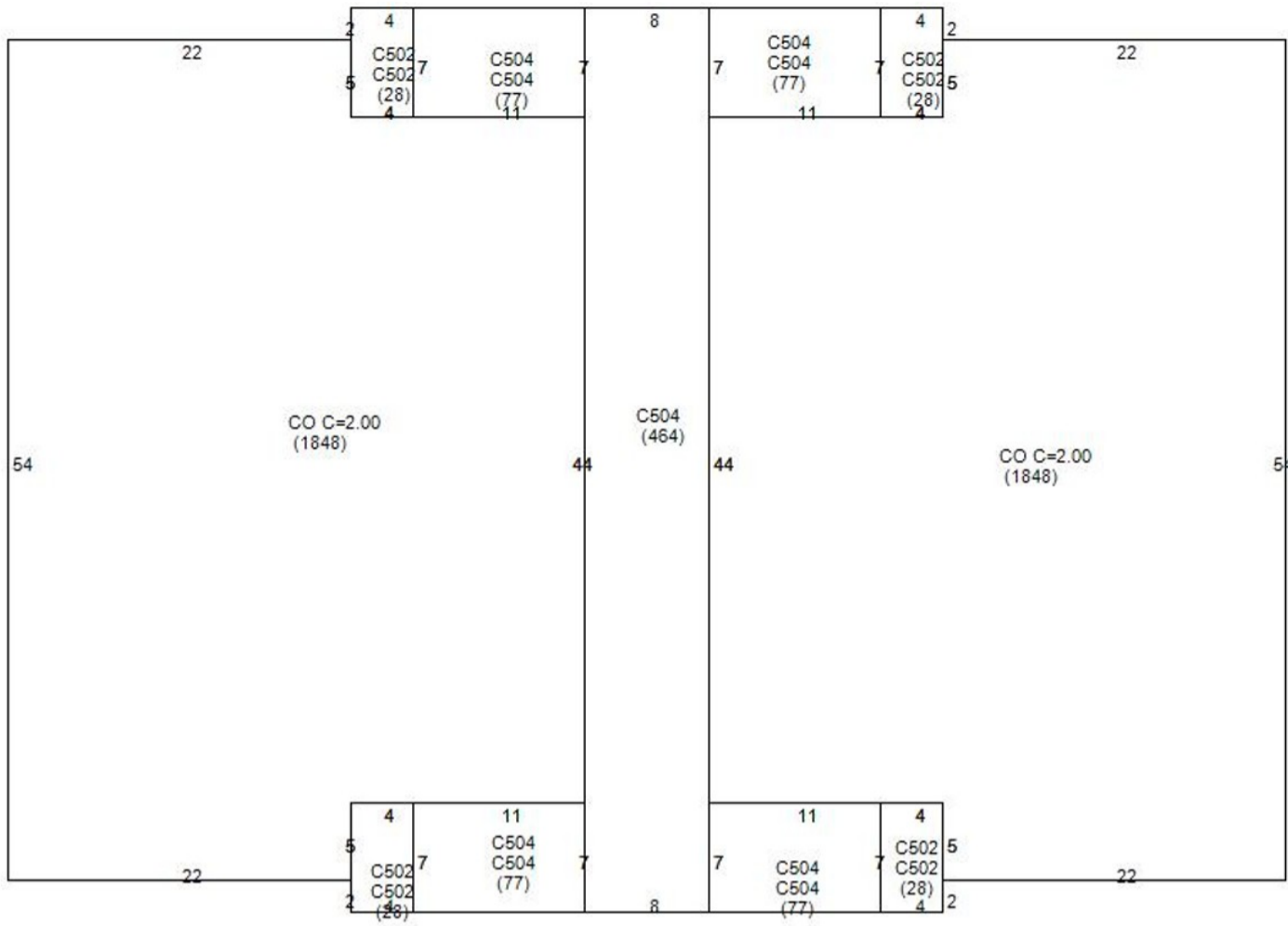

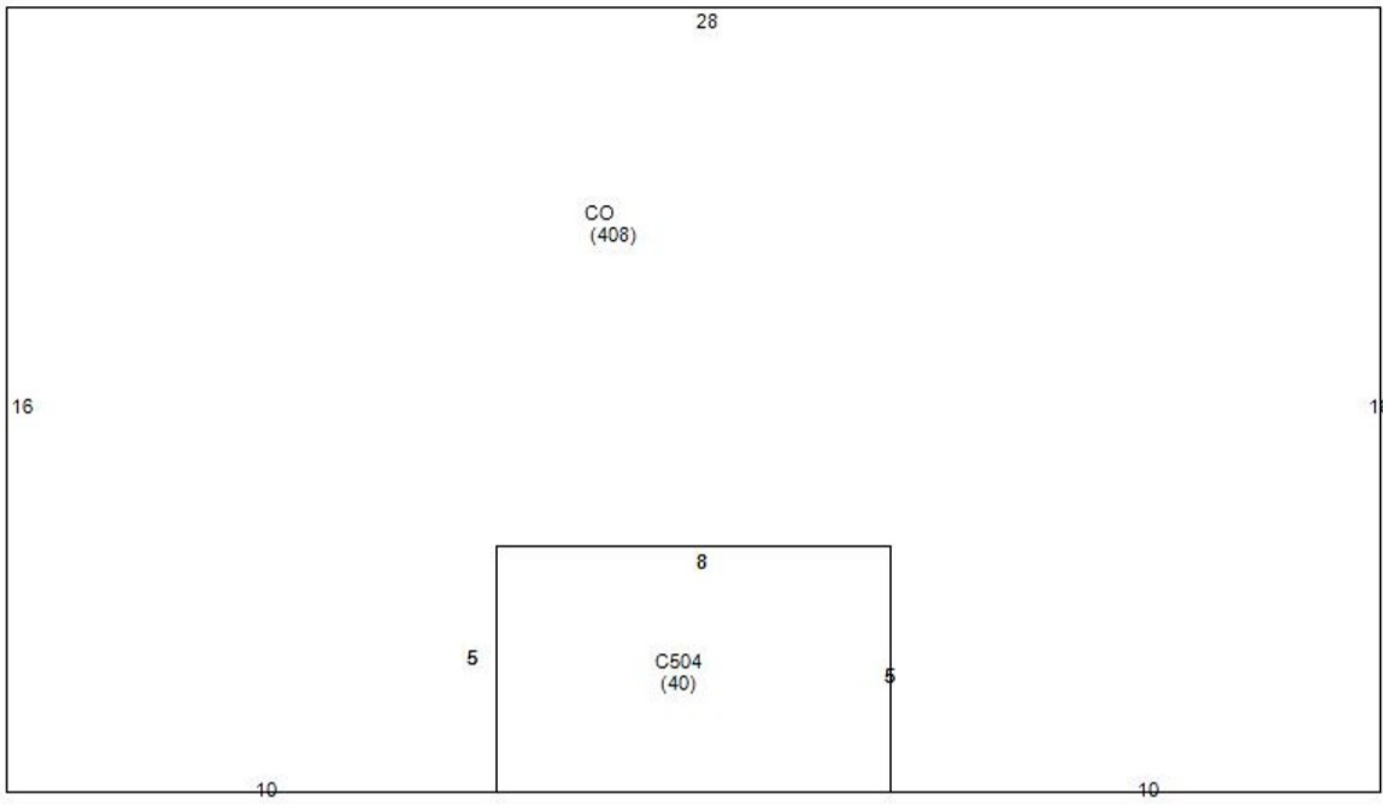

---

#### Disclaimer

Orange County Assessor's Office makes every effort to produce the most accurate information possible. **No warranties, expressed or implied, are provided for the data herein, its use or interpretation.**

<b>BUILDING (1)</b>					
Type	<b>Apt-Multi</b>	Total Value	<b>\$420,500</b>	Finished Sq Ft	<b>12,089 sf</b>
Style	-	Quality	<b>Grade C</b>	Condition	<b>Average</b>
Year Built	<b>1978</b>	Exterior Walls		Full Bath	<b>0</b>
Roof Cover		Half Bath	<b>0</b>	HVAC	
Bedrooms	-	Garage Type	-		

**BUILDING (2)**

**BUILDING (3)**

**BUILDING (4)**

**BUILDING (5)**

**BUILDING (6)**

**BUILDING (7)**

**BUILDING (8)**

**BUILDING (9)**

**BUILDING (10)**

**BUILDING (11)**

**BUILDING (12)**

**BUILDING (13)**

**MISC IMPROVEMENTS**

IMPROVEMENT TYPE	UNITS/SQ FT	EST YEAR BUILT	APPRAISED VALUE
-	1	-	\$1,900
POOL C (KIDD)	200	-	\$11,000
POOL C A180	1800	-	\$40,500

**SALES**

SALE DATE	SALE PRICE	DEED BOOK	DEED PAGE	INSTRUMENT TYPE	GRANTOR
12/14/2017	\$24,136,000	6402	90		CARRBORO II
12/14/2004	\$5,300,000	3631	233		TAR HEEL MANOR ASSOC
12/14/2004	\$5,300,000	3631	233		TAR HEEL MANOR

**YARD ITEMS**

DESCRIPTION	TOTAL UNITS	YEAR BUILT	LENGTH	WIDTH	HEIGHT
No items to display					

# LAND

UNIT / SOIL TYPE	DESCRIPTION	USE CODE	ACRES / LOTS	VALUE
C_AC	Com Acres	SITE	14.38	\$10,209,800

## VALUE HISTORY

YEAR	TOTAL MARKET VALUE
2020	\$11,417,800
2019	\$11,417,800
2018	\$11,417,800
2017	\$11,417,800
2016	\$6,092,189
2015	\$6,092,189
2014	\$6,092,189
2013	\$6,092,189
2012	\$6,092,189
2011	\$6,092,189

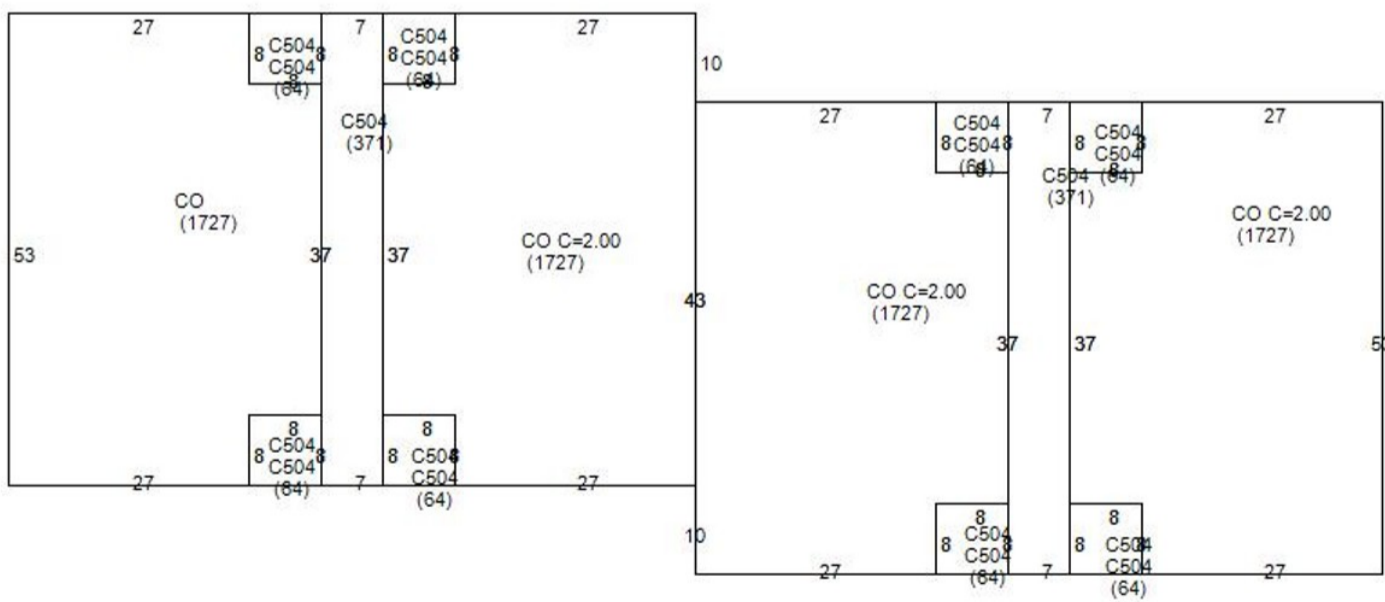

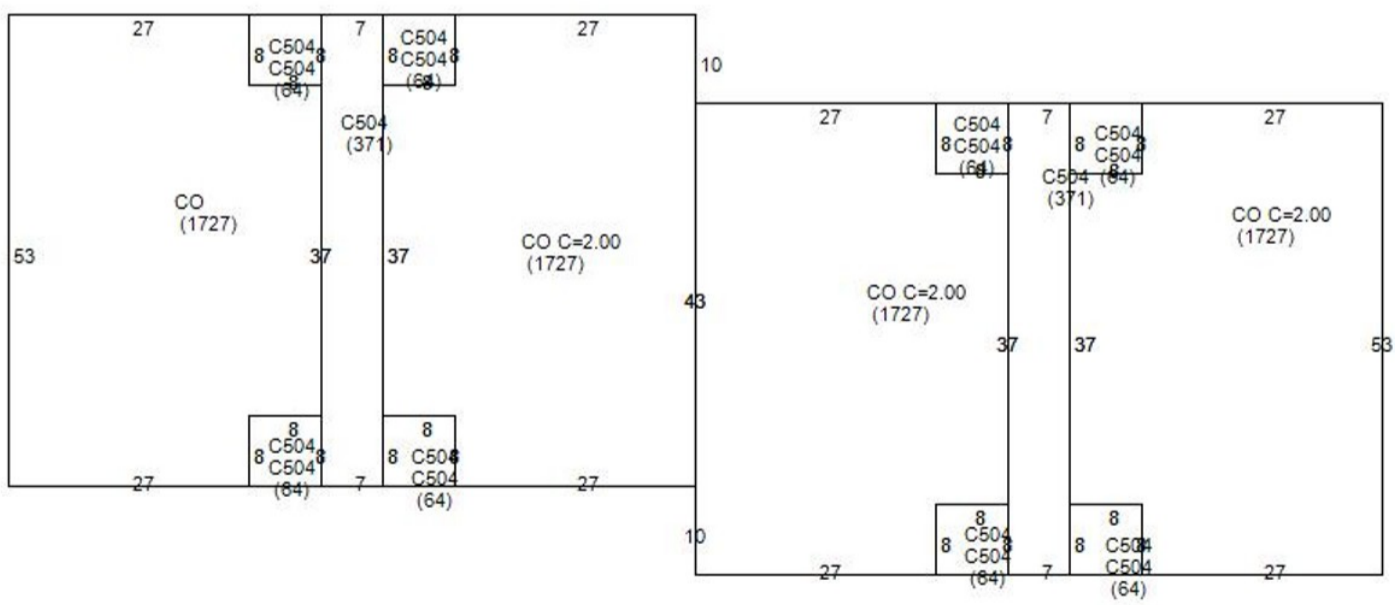
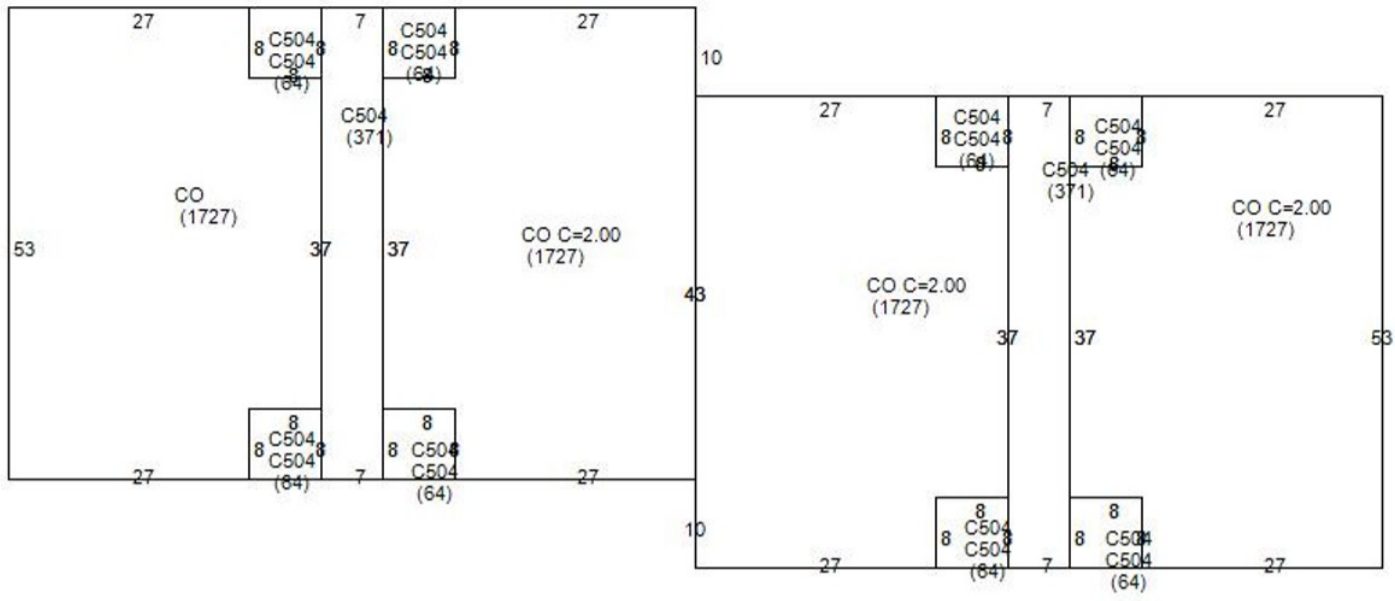

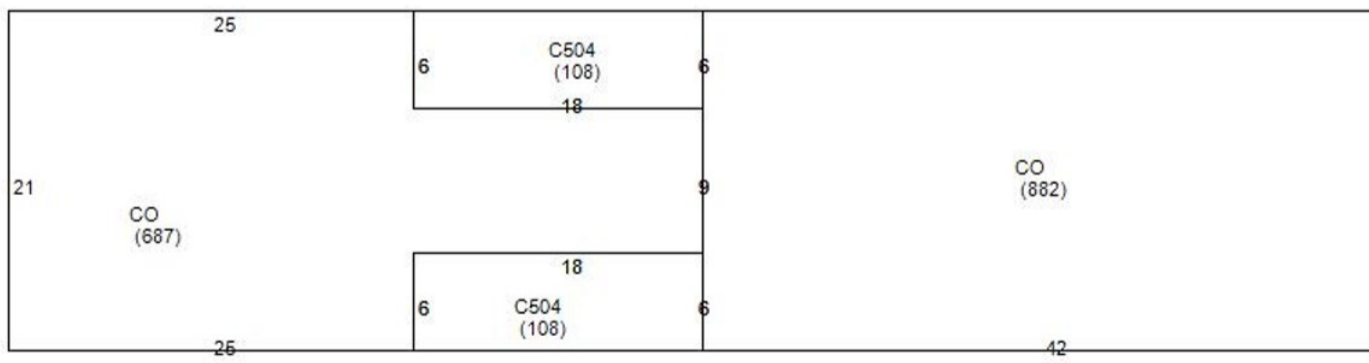
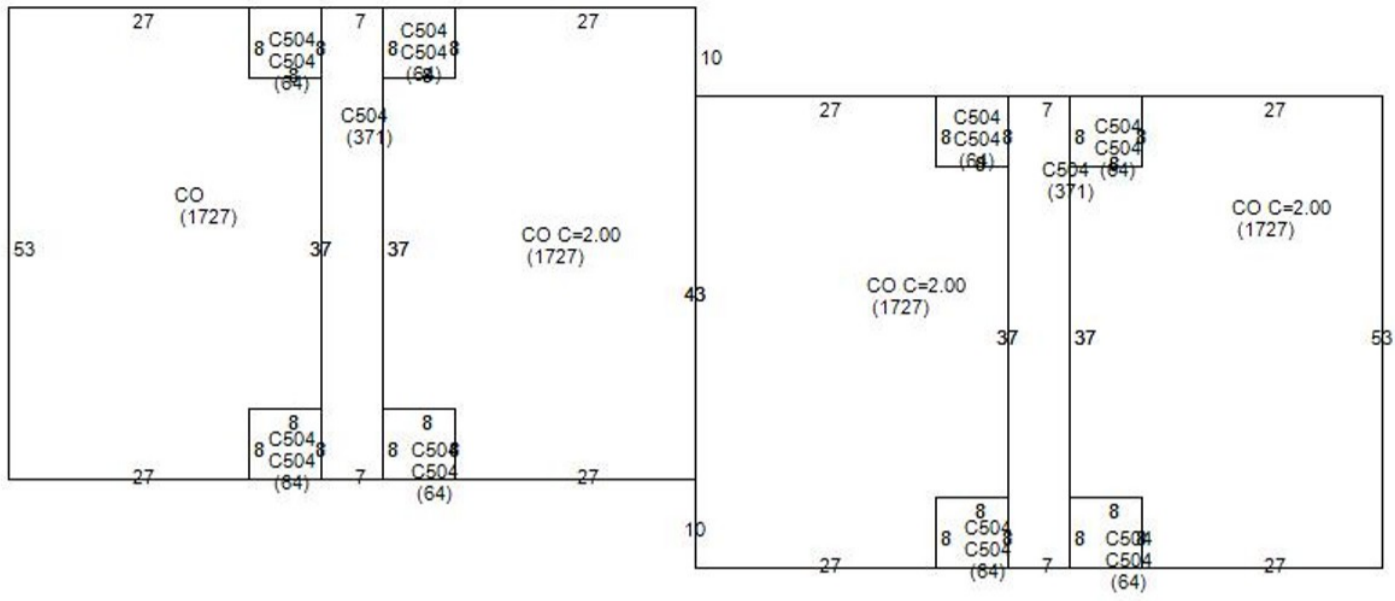

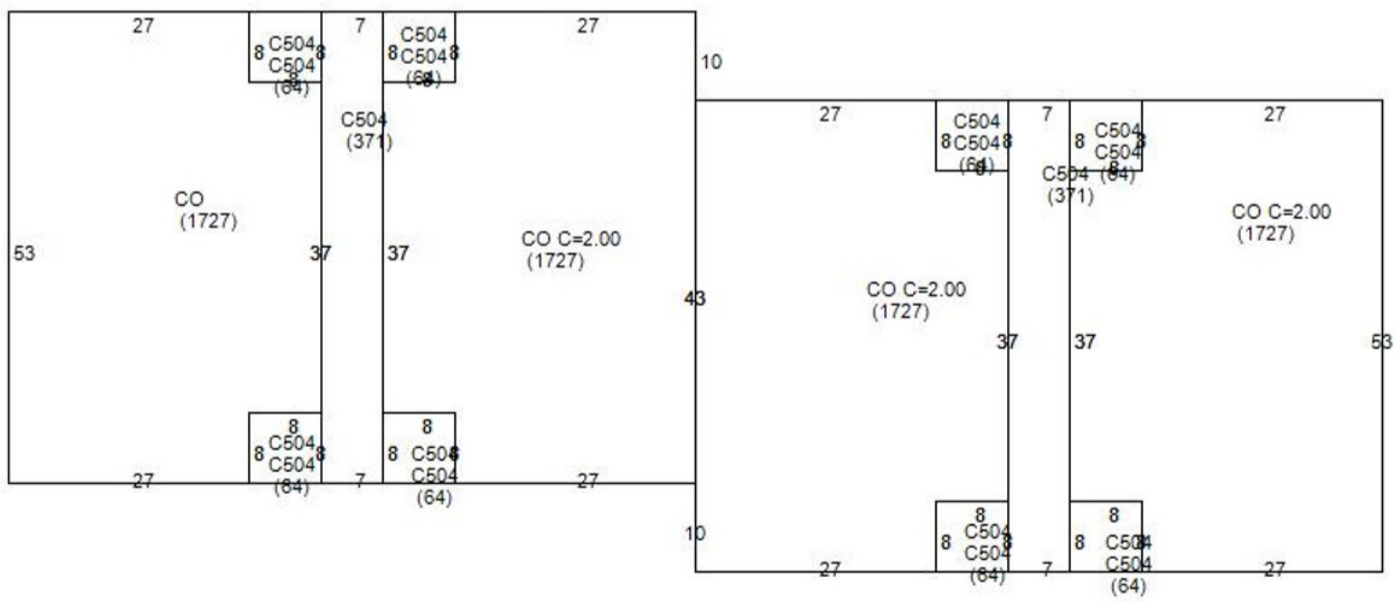
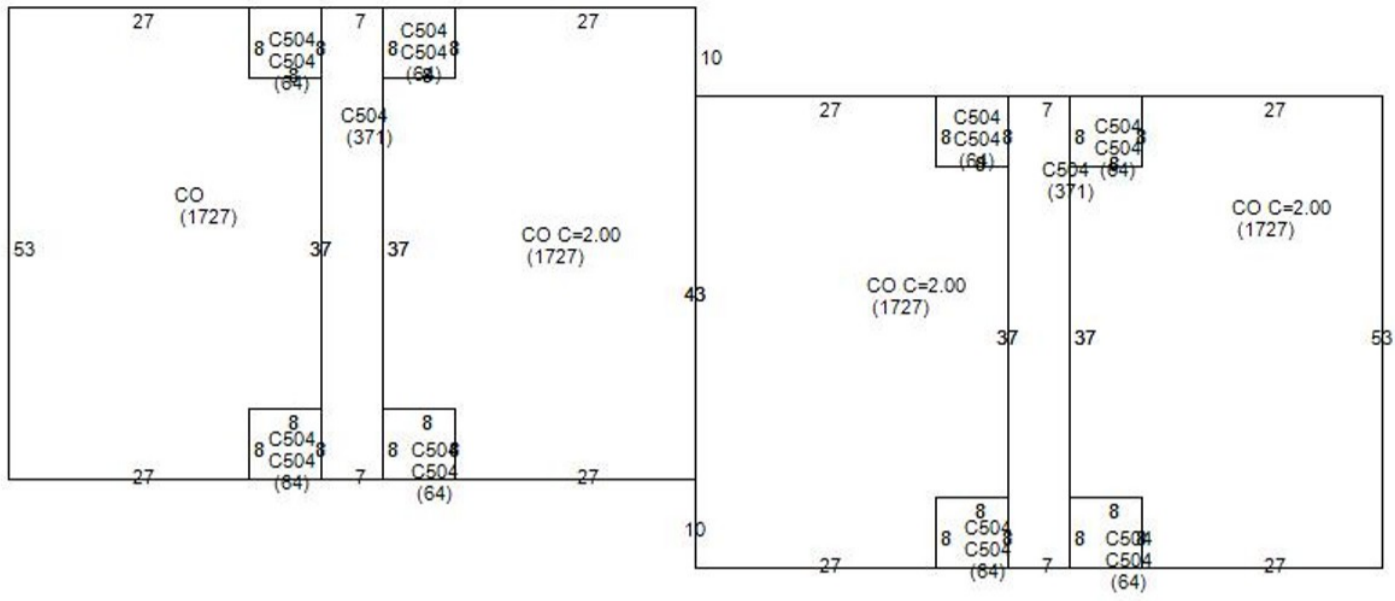

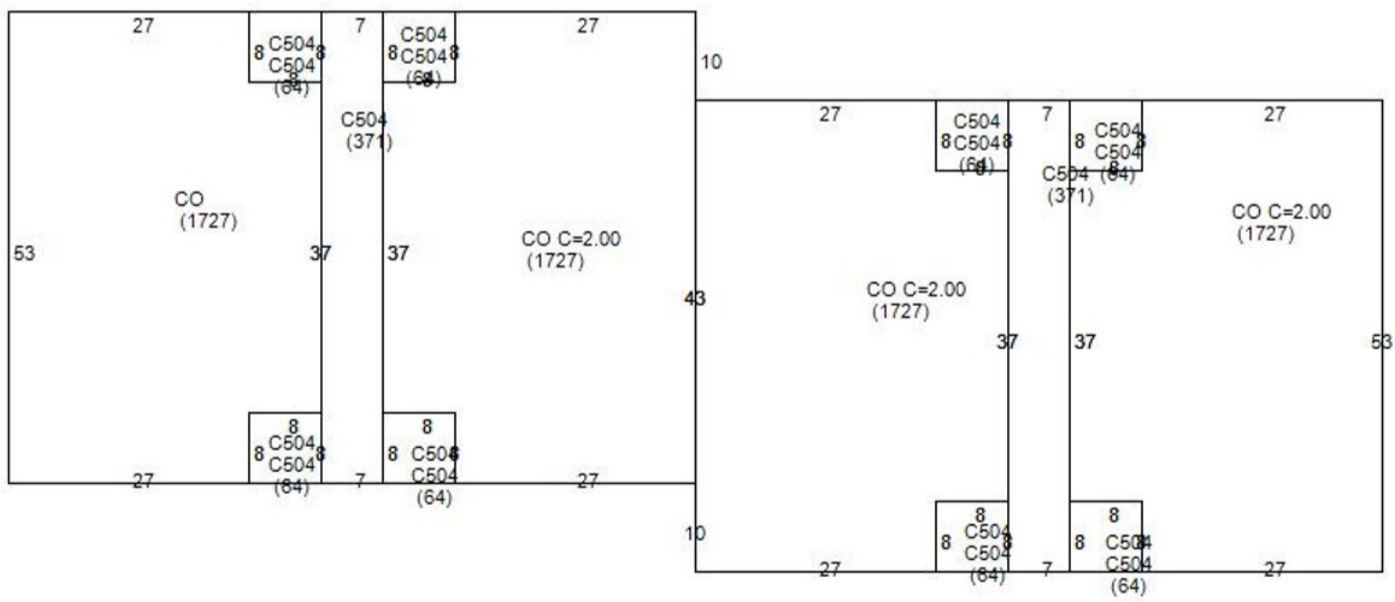
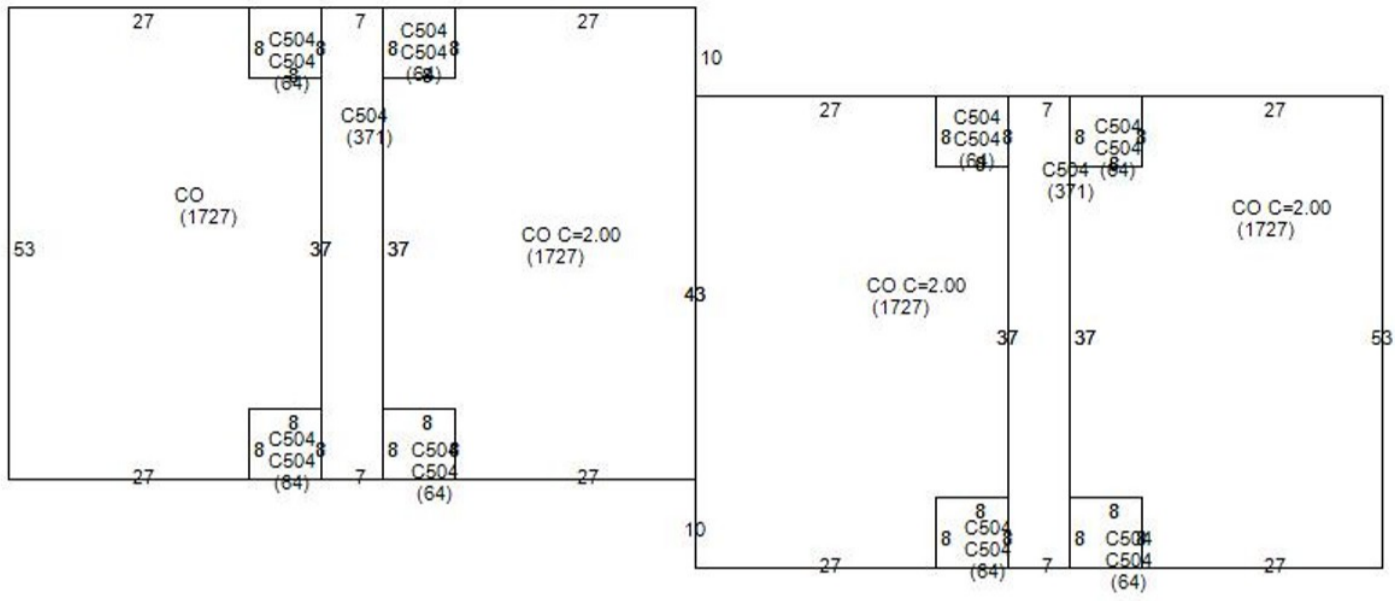

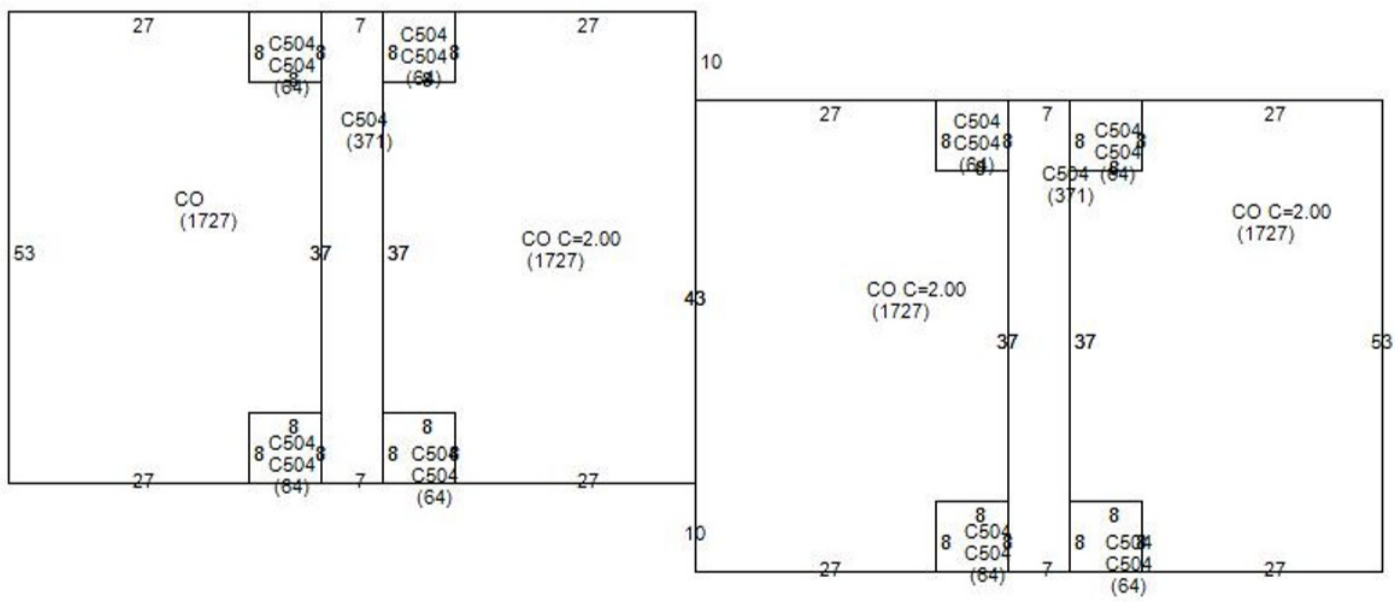
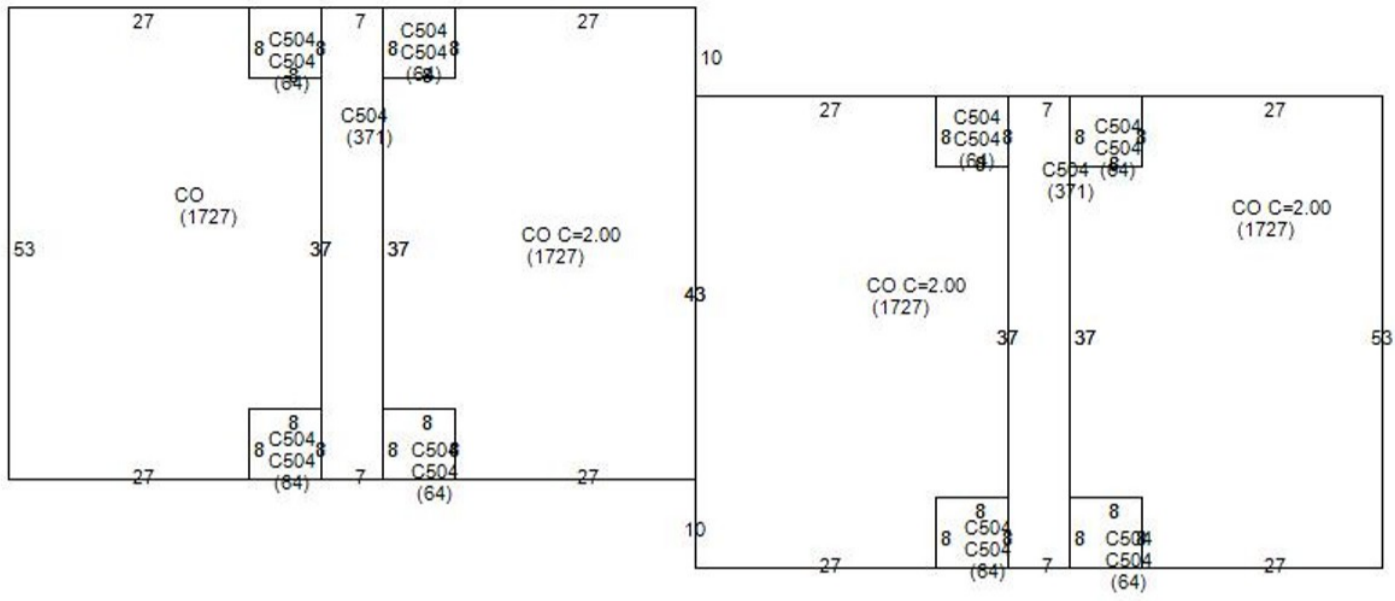

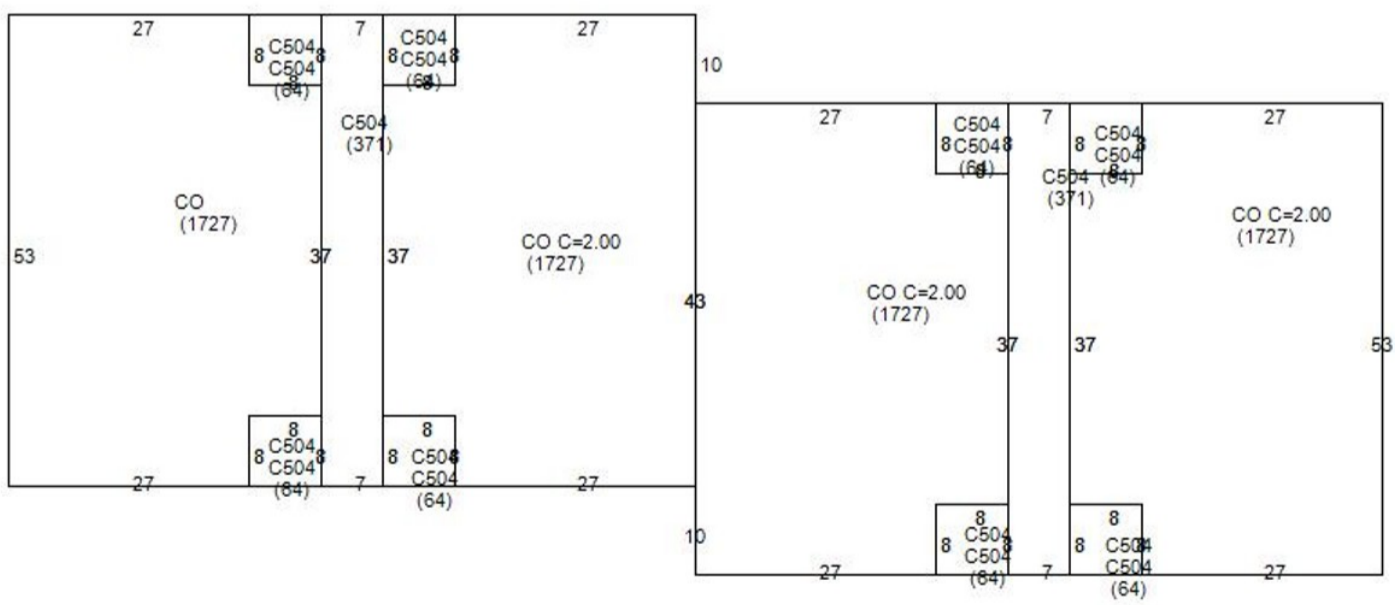
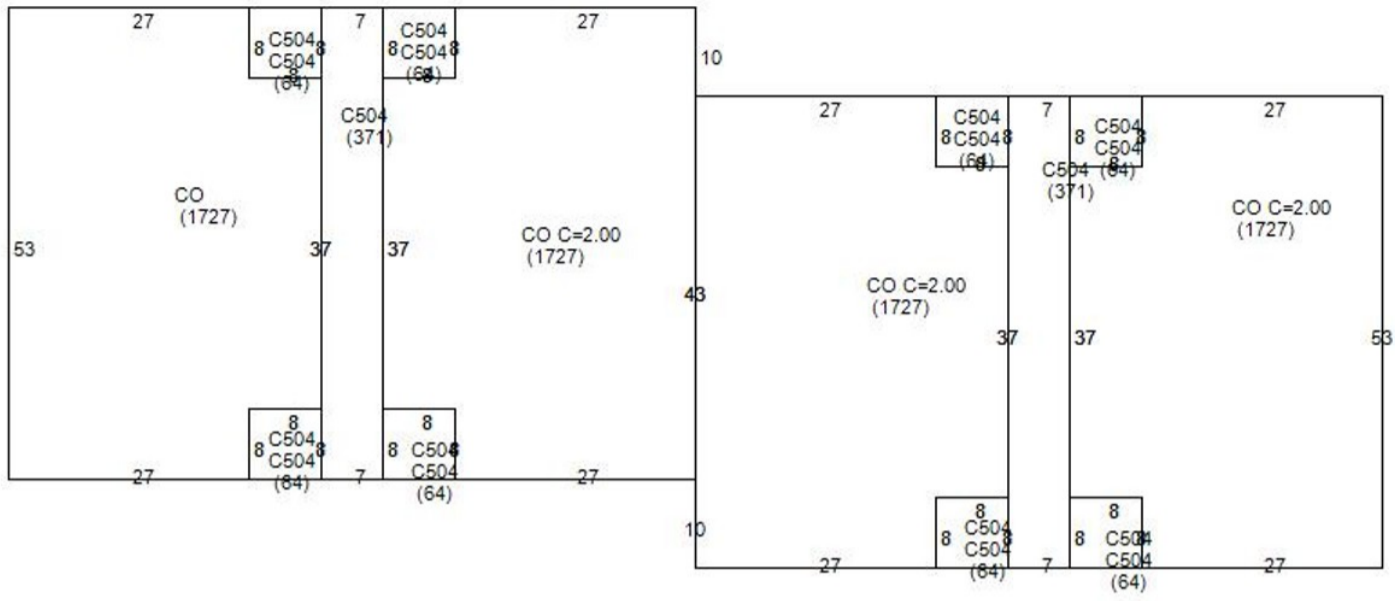

Orange County Assessor's Office makes every effort to produce the most accurate information possible. **No warranties, expressed or implied, are provided for the data herein, its use or interpretation.**